

TEH100 Series

100 Watt Thick Film Power Resistors for High Frequency and Pulse Loading Applications



Ohmite offers the totally encapsulated and insulated TO-247 package for low ohmic value and non-inductive design for high-frequency and pulsing applications. Ideal use is for power supplies. This series is rated at 100 Watts mounted to a heat sink.

FEATURES

- 100 Watt power rating at 25°C case temperature
- Non-inductive performance
- Low thermal resistance
- RoHS compliant design
- TO-247 package configuration
- Single screw mounting simplifies attach-ment to the heat sink
- A totally molded housing for enviromental protection
- Non-Inductive design
- Resistor package totally insulated from heat sink

CHARACTERISTICS

Resistor	thick film on alumina
Case	high temperature plastic
Lead Material	Tinned Copper
Installation, max. Torque	0.9 Nm using an M3 screw and a compression washer
Derating	linear, 100% at 25°C to 0% at 175°C
Resistance range	0.05Ω to 1MΩ, other values on request
Resistance tol.	±1%, ±2%, ±5%, ±10%
Max. working voltage	350V
Temperature Coefficient	>10Ω: 50ppm/°C, ref. to 25°C 3 to 10Ω: 100ppm/°C 1 to 2.99Ω: 250ppm/°C <1Ω: 500-1000+ppm/°C (Contact factory for exact values below 1Ω)
Insulation Resistance	10GΩ min.
Dielectric Strength	1,800 VAC

Test	Conditions Of Test	Performance
Load life	MIL-R-39009D 4.8.13 , 2,000 hours at rated power	$\Delta R \leq \pm(1.0\% + 0.0005\Omega)$
Moisture resistance	-10°C - +65°C, RH>90%, cycle 240 h	$\Delta R \leq \pm(0.50\% + 0.0005\Omega)$
Short time overload	1.5 times rated power and V(DC) $\leq 1.5V_{max}$ for 5 seconds	$\Delta R \leq \pm(0.50\% + 0.0005\Omega)$
Thermal shock	GJB360A-96 method 107, Cond. F	$\Delta R \leq \pm(0.50\% + 0.0005\Omega)$
Dielectric strength	GJB360A-96 method 301, (1,800V AC, 60s)	$\Delta R \leq \pm(0.15\% + 0.0005\Omega)$
Terminal strength	GJB360A-96 method 211, Cond. A (Pull Test) 2.4N	$\Delta R \leq \pm(0.20\% + 0.0005\Omega)$
High frequency vibration	GJB360A-96 method 204, Cond. D	$\Delta R \leq \pm(0.40\% + 0.0005\Omega)$

Derating

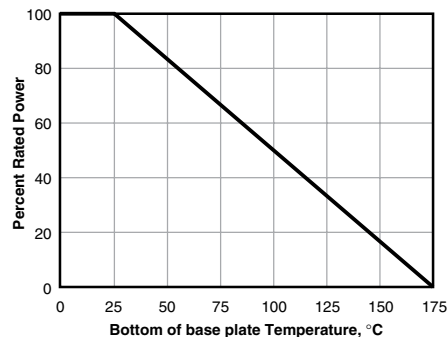

THIS PRODUCT IS DESIGNED FOR USE WITH PROPER HEATSINKING.

Maximum base plate temperature of the resistor must be monitored and kept within specified limits to establish the power rating. Best technique is to attach a thermocouple to the side of the base plate of the resistor. Temperature of plastic housing or heat sink cannot be used to establish rating of the resistor.

Derating (thermal resistance): 0.666W/°K (1.5K/W). Without a heatsink, when in free air at 25°C, the TEH100 is rated for 3.5W. Derating for temp. above 25°C is 0.0234W/°K.

Graphed value is only valid when using a thermal conduction to the heatsink $R_{th-cs} < 0.025^\circ K/W$. This value can be reached by using thermal transfer compound with a heat conductivity of 1W/mK. The flatness of the cooling plate must be better than 0.05mm overall. The roughness of the surface should not exceed 6.4μm. The case temperature is to be used for the definition of the applied power limit. The case temperature measurement must be made with a thermocouple contacting the center of the component mounted on the designed heat sink. Thermal grease should be applied properly

(continued)

TEH100 Series

100 Watt Thick Film Power Resistors for High Frequency and Pulse Loading Applications

DIMENSIONS

(in./mm)

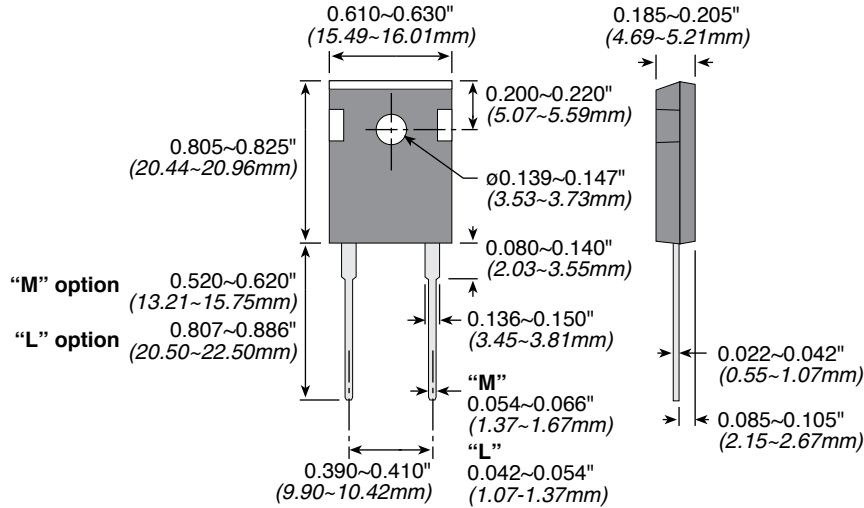

ORDERING INFORMATION

Package Code
M = standard
L = long terminals

RoHS Compliant
Non-compliant
version unavailable

TEH100M10R0JE

Series Ohms Tolerance
R = Decimal F = 1%
Example: J = 5%
2R50 = 2.50Ω
25R0 = 25Ω
100R = 100Ω
1K00 = 1000Ω

Standard part numbers

Ohms	5% tolerance	1% tolerance
0.05	TEH100MR050JE	
0.075	TEH100MR075JE	
0.1	TEH100MR100JE	
0.2	TEH100MR200JE	
0.5	TEH100MR500JE	
1	TEH100M1R00JE	TEH100M1R00FE
2	TEH100M2R00JE	TEH100M2R00FE
2.5	TEH100M2R50JE	TEH100M2R50FE
3	TEH100M3R00JE	TEH100M3R00FE
5	TEH100M5R00JE	TEH100M5R00FE
7.5	TEH100M7R50JE	TEH100M7R50FE
10	TEH100M10R0JE	TEH100M10R0FE
15	TEH100M15R0JE	TEH100M15R0FE
20	TEH100M20R0JE	TEH100M20R0FE
25	TEH100M25R0JE	TEH100M25R0FE
50	TEH100M50R0JE	TEH100M50R0FE
100	TEH100M100RJE	TEH100M100RFE
270	TEH100M270RJE	
470	TEH100M470RJE	
750	TEH100M750RJE	
1K	TEH100M1K00JE	
5K	TEH100M5K00JE	
7.5K	TEH100M7K50JE	